

OPERATION MANUAL FOR HEAT NIPPERS

Models: HT120, HT130, HT140, HT160



(CAUTION)

Thank you for purchasing our Heating Nippers. Please read this operation manual thoroughly before using and follow all instructions correctly in operation. You should keep this manual always afterward.



Caution, electricity

- Don't leave the nipper with power on for long time. Accumulated heat may cause firing.
- Never touch the cutting blades. The temperature at the blade edges comes up over 150°C and may cause heat burn.



Caution: hot

- Don't use the water-wet nipper or with wet hands. Heat burning can occur.
- Don't use the nipper for extremely too long time. Low temperature burn can occur.
- When operating the nipper for more than 8 hours, cut the power and leave the nipper until it gets perfectly cooled down before re-use. (Too long operation will cause some technical troubles with the nipper.)

OUTLINE OF HEATING NIPPERS

MERRY-brand Heating Nippers are set with cutting blades, which can be heated to cut fragile Resin (such as Acryl, Styrene, Glass-containing Resin, etc.) without cracking. Any other general Resin can be cut with less operating power.

(HOW TO USE)

- 1) Turn the center wall of the designated Tool Stand up as below illustrated.

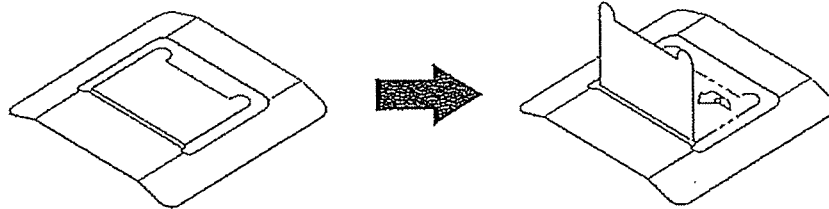

- 2) Connect the power code of Transformer to power source.
 - 3) Connect the plug of Heat Nipper to Transformer.
 - 4) Set the Heat Nipper on Tool Stand and heat the tool until it gets sufficiently warm.
 - 5) Adjust temperature adequately by turning the High-Low thumb on Transformer.
 - 6) Pick up the tool after the temperature reaches at suitable level and operate.
Never touch the highly heated cutting blade.
- Heat Nippers cannot be used at electric voltage of higher than 24V.
 - Use our model TRF-25 (100, 220~240V) Transformer to lower the operation voltage.
 - The adjusted temperature reaches to the max. after heating about 25 minutes at normal ambient temperature.
 - The cutting blades suit cutting only resin. Do not cut metal and any other material than resin.
 - In case of accidental touch on the heated cutting blades, cool the body spots with water immediately and consult with a medical doctor without delay.
 - When any abnormality occurs while operating, turn off power immediately and do not operate the tool until fixing.
 - Use Tool Stand to carry and transfer the heated Nipper.
 - Do not point the heated Nipper to other peoples.
 - Do not use Heat Nippers for other purposes out of rated application.

(When Blades become hard to open and shut)

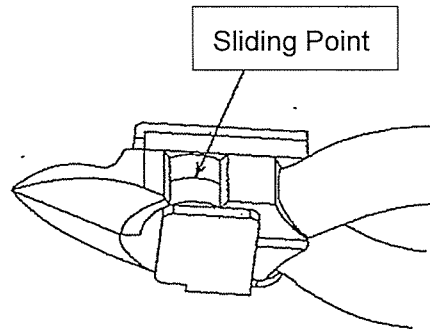

After using HEAT Nippers for long time, lubricant on the sliding contact of the Cutting Blades evaporates out to cause unsmooth open/shut actions. Supply one or two drops of lubricant (machine oil) to the Cutter sliding contact and operate the tool until the Cutting Blades moves smooth.

(How to replace the Heaters)

Follow the below guided steps to avoid wire snapping.

- 1) Shut off power supply and cool the Heat Nippers perfectly.
- 2) Unloosen the Nut (#15) and remove the Screw (#12).
- 3) Unloosen the Holder Setting Screw (#11) and remove the Heater Holder (#6).
- 4) Be sure to hold the power plugs of the Heaters and pull off the Heater Connector. (Never hold the wire to avoid snapping of wire.)
- 5) Be careful not to be injured with the tip or sharp edge of Cutter Blades when replacing the Heaters.

(Images of Cutting Blades of Heat Nippers)

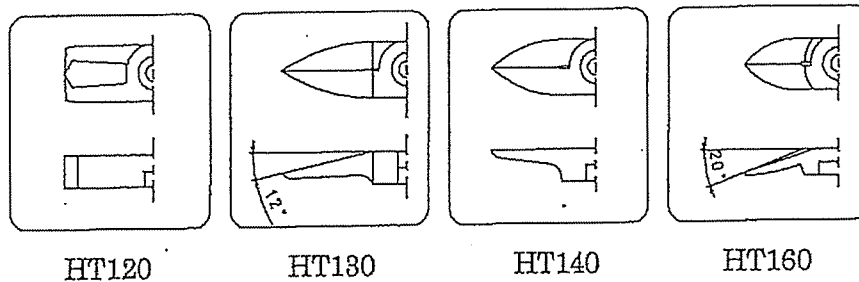

HT120

HT130

HT140

HT160

(Parts list of Heat Nippers)

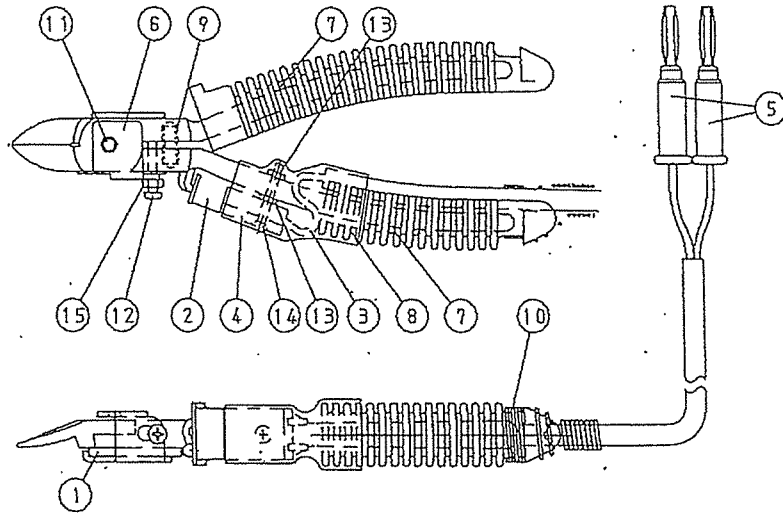

No.	Name of parts	Q'ty
1	W19 Heater Ass'y	1
2	Heater Plug	1
3	Code Ass'y (c/w. 4,5,10,13,14)	1set
4	Connector Ass'y (c/w. 13,14)	1set
5	Banana Plug (red & black)	1set
6	Heater Holder	1
7	Heat Nipper Cover (R, L)	1set
8	Heat Shrink Tube	1

No.	Name of parts	Q'ty	Q'ty
9	Spring ※		1
10	Code Holding Spring		1
11	Holder Set-Screw		1
12	Screw (c/w. 15)		1set
13	Nut (2pcs.)		1set
14	Countersunk Screw		1

Accessory: Designated Tool Stand

※ "Spring" for HT120, HT130 and HT140 must be ordered with P/No.MBN-07 by pack of 10 pcs.

※ "Spring" for HT160 must be ordered with P/No.MBN-05 by pack of 10 pcs.

MUROMOTO TEKKO CO. LTD.

OPERATION MANUAL FOR HEAT NIPPERS

Models: HT170, HT180



(CAUTION)

Thank you for purchasing our Heating Nippers. Please read this operation manual thoroughly before using and follow all instructions correctly in operation. You should keep this manual always afterward.



Caution, electricity

- Don't leave the nipper with power on for long time. Accumulated heat may cause firing.
- Never touch the cutting blades. The temperature at the blade edges comes up over 150°C and may cause heat burn.



Caution: hot

- Don't use the water-wet nipper or with wet hands. Heat burning can occur.
- Don't use the nipper for extremely too long time. Low temperature burn can occur.
- When operating the nipper for more than 8 hours, cut the power and leave the nipper until it gets perfectly cooled down before re-use. (Too long operation will cause some technical troubles with the nipper.)

OUTLINE OF HEATING NIPPERS

MERRY-brand Heating Nippers are set with cutting blades, which can be heated to cut fragile Resin (such as Acryl, Styrene, Glass-containing Resin, etc.) without cracking. Any other general Resin can be cut with less operating power.

(HOW TO USE)

- 1) Turn the center wall of the designated Tool Stand up as below illustrated.

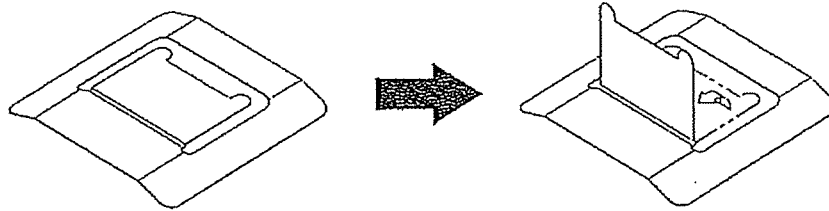

- 2) Connect the power code of Transformer to power source.
 - 3) Connect the plug of Heat Nipper to Transformer.
 - 4) Set the Heat Nipper on Tool Stand and heat the tool until it gets sufficiently warm.
 - 5) Adjust temperature adequately by turning the High-Low thumb on Transformer.
 - 6) Pick up the tool after the temperature reaches at suitable level and operate.
Never touch the highly heated cutting blade.
- Heat Nippers cannot be used at electric voltage of higher than 24V.
 - Use our model TRF-25 (100, 220~240V) Transformer to lower the operation voltage.
 - The adjusted temperature reaches to the max. after heating about 25 minutes at normal ambient temperature.
 - The cutting blades suit cutting only resin. Do not cut metal and any other material than resin.
 - In case of accidental touch on the heated cutting blades, cool the body spots with water immediately and consult with a medical doctor without delay.
 - When any abnormality occurs while operating, turn off power immediately and do not operate the tool until fixing.
 - Use Tool Stand to carry and transfer the heated Nipper.
 - Do not point the heated Nipper to other peoples.
 - Do not use Heat Nippers for other purposes out of rated application.

(When Blades become hard to open and shut)

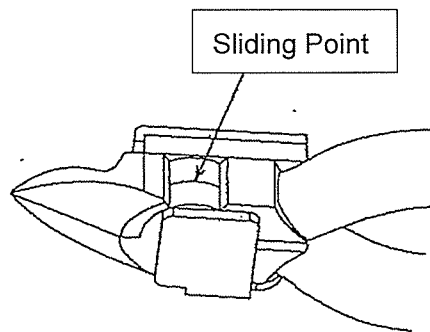

After using HEAT Nippers for long time, lubricant on the sliding contact of the Cutting Blades evaporates out to cause unsmooth open/shut actions. Supply one or two drops of lubricant (machine oil) to the Cutter sliding contact and operate the tool until the Cutting Blades moves smooth.

(How to replace the Heaters)

Follow the below guided steps to avoid wire snapping.

- 1) Shut off power supply and cool the Heat Nippers perfectly.
- 2) Unloosen the Nut (#15) and remove the Screw (#12).
- 3) Unloosen the Holder Setting Screw (#11) and remove the Heater Holder (#6).
- 4) Be sure to hold the power plugs of the Heaters and pull off the Heater Connector. (Never hold the wire to avoid snapping of wire.)
- 5) Be careful not to be injured with the tip or sharp edge of Cutter Blades when replacing the Heaters.

(Images of Cutting Blades of Heat Nippers)

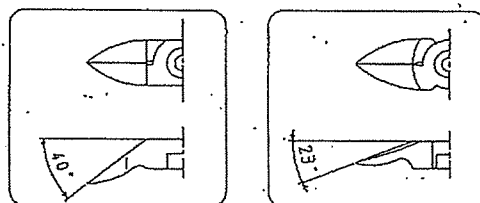

HT170

HT180

(Parts list of Heat Nippers)

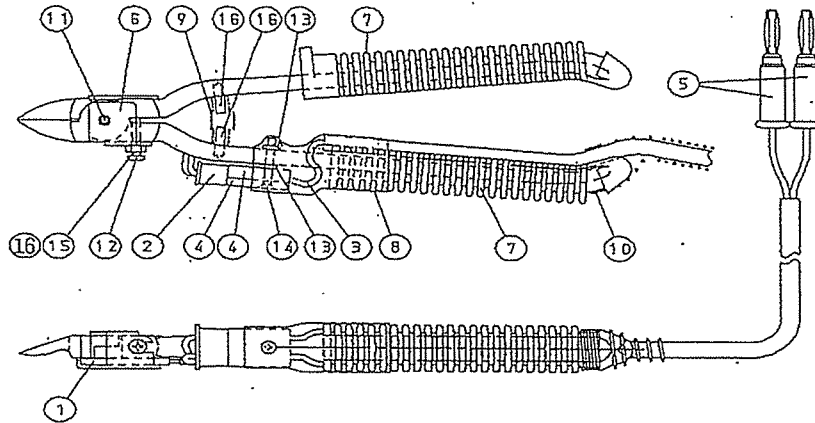

No.	Name of parts	Q'ty
1	W19 Heater Ass'y	1
2	Heater Plug	1
3	Code Ass'y (c/w. 4,5,10,13,14)	1set
4	Connector Ass'y (c/w. 13,14)	1set
5	Banana Plug (red & black)	1set
6	Heater Holder	1
7	Heat Nipper Cover (R, L)	1set
8	Heat Shrink Tube	1

No.	Name of parts	Q'ty	Q'ty
9	Spring ※		1
10	Code Holding Spring		1
11	Holder Set-Screw		1
12	Screw (c/w. 15)		1set
13	Nut (2pcs.)		1set
14	Countersunk Screw		1
15	Nut		1
16	Roll Pin		2

Accessory: Designated Tool Stand

※ "Spring" for HT180 must be ordered with P/No.MBN-08 by pack of 10 pcs.

※ "Spring" for HT170 must be ordered with Spring for HT170 by 1 pc.

MUROMOTO TEKKO CO. LTD.